

Our associates will ensure the tool works properly before you leave the store. If you experience issues with the tool while completing your project, simply bring it back to the Tool Rental Center to get a replacement. If you purchase Damage Protection at the time of your rental, you are not responsible for repair costs for tools that break due to normal use.

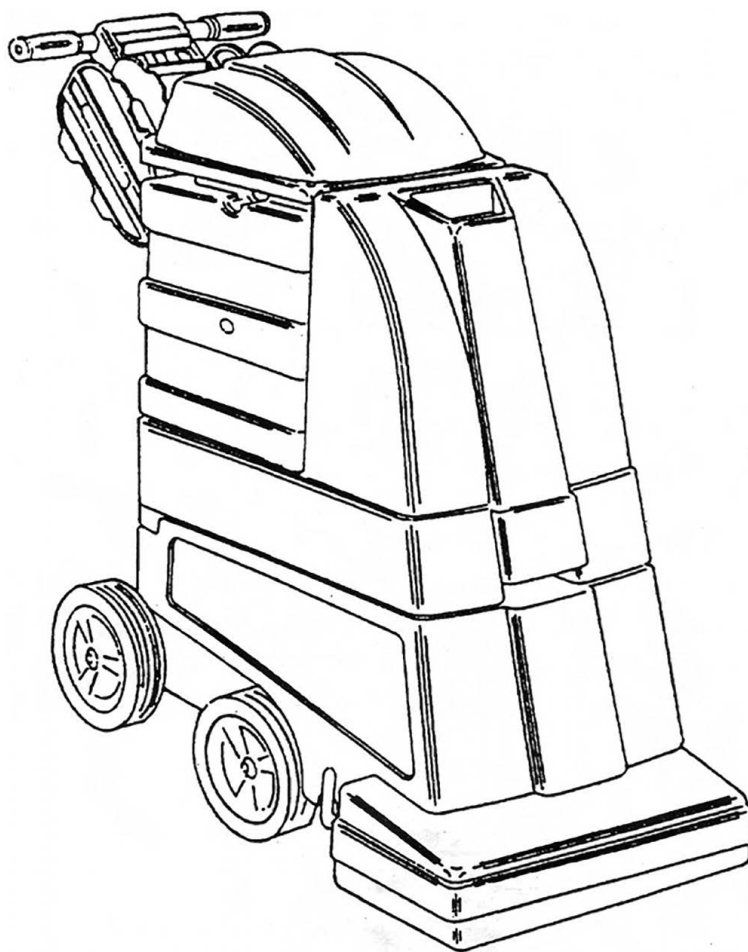

POLARIS AND SUPERNOVA OWNER'S MANUAL & PARTS LIST

This equipment is intended for commercial use only.



POLARIS 800 & 1200 SUPERNOVA 800 & 1200



BEFORE OPERATING THE MACHINE

Read the manual carefully and completely before attempting to operate the unit. This manual has important information for the use and safe operation of the machine. Keep this manual handy at all times. This machine will ensure years of satisfactory service if operated and maintained according to recommendations in the manual. If additional information is needed, please contact your local distributor or write to:

EDIC
1753 Blake Avenue
Los Angeles, California 90031-1006

All information and specifications printed in the manual and parts list are current at the time of printing; however, because of EDIC's policy of continual product improvement, we reserve the right to make changes at any time without notice.

This machine is shipped with antifreeze in the solution line system to protect the pump and valves from freezing during transport and storage. Before you use the unit, rinse the solution line system with clean water (See Preparing The Machine).

WARNING

- The machine was designed for use on carpet, floor and upholstery extraction application as per instructions and recommendations written in this manual. Any deviation from its proper use or purpose and the consequential damage that may occur is the sole responsibility of the end user.
- Disconnect the power cord from outlet before servicing. Do not leave machine connected to an electrical outlet when unattended.
- Do not immerse or use this machine in standing water. Such use may cause electric shock.
- This equipment is not designed to handle or use combustible/volatile substance such as gasoline or kerosene, in, on, or near the machine. The use of such materials will cause an extreme hazard condition.
- When using an extension cord, use only a 3 conductor grounding cord—12 ga. wire or heavier.
- To avoid electric shock, do not expose the unit to rain—store it indoors only.
- Do not use the machine for dry vacuuming. This machine is not outfitted with a fine dust filter and it will damage the vacuum motor(s).

- Use defoamer at all times to prevent damage to the vacuum motor(s).
- Do not use water in excess of 140°F (62°C).
- Use only commercially available carpet cleaners and defoamer intended for use with machines of this type. Do not use dyes, bleaches, ammonia or other additives. The use of powdered cleaning solution if not diluted properly made result in damage to the pump.
- Do not expose machine to freezing temperatures.
- All repairs must be done by an authorized EDIC repair station.
- Do not use replacement parts other than those specified in the parts list.

FAILURE TO COMPLY WITH THE ABOVE WARNING INSTRUCTIONS WILL VOID THE WARRANTY.

GROUNDING INSTRUCTIONS

The 120 V. A/C and the 220 V. A/C models have been outfitted with the appropriate grounded connectors. Make sure the machine is connected to a grounded outlet having the same configuration as the grounded plug. No adapter should be used with this machine. Any modification to the connectors will void the warranty.

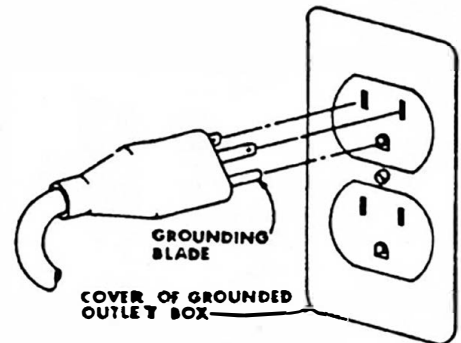

PREPARING THE MACHINE

1. Rinse then fill the recovery pails with clean hot tap water (not to exceed 140°F). When pouring water, make sure drain hose is clipped in the upright position. Pour the water into the solution tank.
2. Add recommended amount of cleaning solution to the tank, follow mixing directions on label for best results.
3. Set the recovery pails back in place. Add recommended amount of defoamer to the recovery pails. Close the lid.

TO CLEAN CARPET

1. Connect machine to a grounded electrical outlet.
2. Turn on the VACUUM, PUMP and BRUSH switches.
3. Lift up on the handle grips to insure that the front of the machine rests on the carpet. Slowly pull the machine backwards while pressing on the carpet spray switch (below the left handle grip). Monitor the extraction process through the vacuum lid. Release the spray switch 6 inches before ending the stroke.

NOTE: On Supernova models the "Activate" switch operates the solution release and brush. Use the direction lever to operate the machine in the direction you wish to clean.

NOTE: If dirty solution does not appear through the vacuum lid check to be sure if:

- The vacuum lid is resting properly on the recovery pails
- The machine's nose is touching the carpet in the working mode.
- The solution tank is not empty.

4. Roll the machine forward on its four wheels for next stroke. Make overlapping passes to prevent streaking. Check solution level from time to time (see solution indicator tube on rear left corner of the back).

NOTE: If foam appears on vacuum lid, turn the VACUUM SWITCH OFF IMMEDIATELY. Add more defoamer to the recovery pails to dissolve foam or empty the recovery pails.

5. When the solution tank runs empty, turn off the vacuum, pump and brush switches. Empty the recovery pail and rinse thoroughly. Then repeat steps on PREPARING THE MACHINE.

TO ATTACH ACCESSORY HOSE

1. Remove 2" hose adapter connection from machine.
2. Attach 1 1/2" assembly with adapter plate to vacuum lid inlet.
3. Pull back female quick disconnect sleeve on the machine and insert male plug on the solution hose.

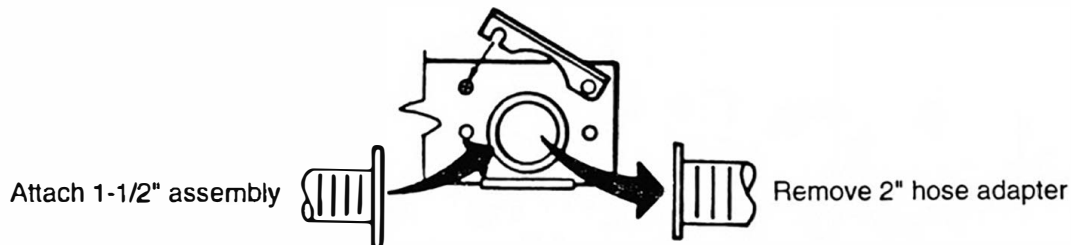

TO EMPTY THE SOLUTION TANK

1. Unhook the drain nozzle (located on the side of the machine from the drain clips), placing the end of the hose into the recovery pails.

AFTER EACH USE

- Empty and thoroughly rinse the recovery pails.
- Coil power cord onto the cord wrap.
- Remove dirt and lint build-up inside vacuum lid filter screen.
- Clean solution line filter.
- Wash the vacuum lid with a soap solution and sponge to prevent dirt from accumulating on the surface. (To avoid scratching use soft cloth only).
- Lean the machine back on its 4 wheels during storage or when it's not in use to prevent brush distortion.)

MAINTENANCE

The upright extractor is engineered for minimum maintenance. But it does require some care to keep it in optimum working condition. Careful attention to these maintenance instructions will give you maximum operating performance and life expectancy of the machine.

- Solution line, fittings and accessory tools. —Flush the machine and accessories at least once a month with solution of 1 part water to 3 parts white vinegar to neutralize the alkaline residue left by the cleaning solution.
- Filter Solution screen. —Unscrew bowl and rinse screen in running tap water. If screen is clogged up with soap, soak in vinegar solution and brush clean.
- Vacuum lid screens. —Always keep the screen clean in order to maintain maximum suction and airflow performance from the vacuum motor. The screens also prevent lint from accumulating in the vacuum motor fan chamber thus increasing the productive life of the motor. Do not operate the unit without the screen installed! If the screen gets lost or damaged, replace it immediately.
- Quick disconnect coupler. —Spray with lubricant (WD-40) or equivalent to prevent coupler from sticking.

TROUBLESHOOTING Polaris and Supernova Models

For additional Supernova troubleshooting see page 7 thru 12

ELECTRICAL SYSTEM

PROBLEM	POSSIBLE CAUSE
No electrical power.	<ol style="list-style-type: none">1. Defective power cord.2. House or building circuit breaker trips.
Switch is turned on. Power is intermittent to motor.	<ol style="list-style-type: none">1. Faulty electrical cable.2. Defective Switches.3. Loose terminal or discolored terminal connections.

VACUUM SYSTEM

PROBLEM	POSSIBLE CAUSE
No Vacuum	<ol style="list-style-type: none">1. Vacuum lid is not resting on recovery pail.2. Loose vacuum hose, vacuum connection.
Low Vacuum	<ol style="list-style-type: none">1. Accumulated dirt on lid screen.2. Worn out vacuum lid gasket.3. Lint & dirt build-up on suction head. (brush chamber).4. Defective vacuum hose.5. Loose connection in the vacuum motor.

SOLUTION SYSTEM

PROBLEM	POSSIBLE CAUSE
Pump motor on, no spray thru carpet spray tips or accessory tool	<ol style="list-style-type: none"> 1. Clogged spray tips. 2. Clogged solution intake filter screen. 3. Clogged solenoid valve or open solenoid coil. 4. If carpet spray works normally, plugged up female quick disconnect coupler. 5. Punctured pump diaphragm. 6. Defective pump check valve. 7. Crack in pump housing. 8. Debris in check valve.
Uneven or weak spray from tips.	<ol style="list-style-type: none"> 1. Clogged or dirty spray tips. 2. Accumulated dirt on solution intake filter screen. 3. Accumulation of debris inside pump and plumbing. 4. Worn pump bearing (excessive noise). 5. Punctured pump diaphragm. 6. Defective rectified
Carpet spray is turned off solution still drips from spray tips.	<ol style="list-style-type: none"> 1. Debris caught in between the 3 solenoid valve parts and the plunger.
Vacuum motor working pump motor fails to turn on.	<ol style="list-style-type: none"> 1. Loose "Molex" plug connector. Loose wiring connection. 2. Defective pressure switch in pump motor (100 psi model). 3. Defective pump motor or rectifier.

ROTARY BRUSH SYSTEM

PROBLEM	POSSIBLE CAUSE
Motor runs, brush won't spin.	<ol style="list-style-type: none"> 1. Loose pulley tension. 2. String caught between walls.
Brush motor fails to turn on after circuit breaker has been reset.	<ol style="list-style-type: none"> 1. Defective bridge rectifier. 2. Defective motor.
Floating brush won't move up and down.	<ol style="list-style-type: none"> 1. Debris caught inside the slide block guide.

BRUSH DRIVE BELT SERVICE AND/OR REPLACEMENT (refer to parts diagram).

1. Remove 2 1/4-20 hex screws attaching lower frame to upper frame.
2. On Models 800 & 1200, remove (4) #8-32 screws on the sides of the brush chamber cover
3. Remove (2) spring cover plate assemblies and carefully remove springs from the slide blocks.
4. Loosen (2) 1/4-20 hex screws that hold brush motor bracket in place. Push bracket toward the front of the machine to loosen belt.
5. Remove right Open-End and left Pulley-End cover plates.
6. Slide brush assembly and slide blocks out from their guides. Replace worn and defective belt.
7. Reinstall above components. Clean accumulated lint or debris inside the slide block guides and check for wear on the teflon surfaces. Replace if necessary. The slide block washer (item #36) must be installed between the slide block guide and inside the divider wall. Adjust belt tension by moving motor bracket toward the rear. Apply minimum belt tension when the hex bolts are tightened to allow for a smooth vertical brush movement. A belt too loose will cause the belt to skip when brush is applied on the carpet. A belt too tight won't allow for up and down movement.

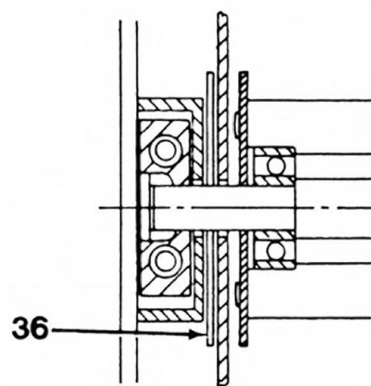

REPLACEMENT OF BRUSH ASSEMBLY AND/OR BEARINGS

1. Repeat steps 1 thru 4.
2. Remove slide blocks from the ends of the brush shaft.
3. Remove (4) screws from string guard. Tap the shaft toward the right open end to remove the bearing.
4. Remove (4) screws from slinger and pull off brush core. Scrape off old sealant build up on the slinger and string guard. It is advisable to replace the two bearings every time the brush is replaced.
5. Reinstall the above componente. CAUTION! Install shorter step on the shaft ends toward the left pulley side. Apply silicon sealant such as GE Silicon auto seal onto the ends of the brush core before reassembling the slinger and string guard.

SUPERNOVA 800 & I200

TROUBLE SHOOTING

VACUUM VALVE

PROBLEM	POSSIBLE CAUSE	SOLUTION
Vacuum Valve, item (8) has an air flow leak.	<ol style="list-style-type: none"> 1. Vacuum valve, item (8) out of adjustment causing vacuum valve seal, item (15), to be incorrectly positioned. 2. Damaged or worn vacuum valve seal, item (15). 3. Broken vacuum valve pull cable, item (23). 4. Loose or broken vacuum valve pull springs, item (25). 5. Damaged vacuum valve guide face gasket, item (15). 6. Damaged vacuum valve pressure balls, item (12), or vacuum valve pressure ball springs, item (13). 	<p>Readjust. See Vacuum valve pull cable adjustment procedure.</p> <p>Replace.</p> <p>Replace.</p> <p>Reconnect or, if broken, replace.</p> <p>Replace.</p> <p>Replace.</p>
Vacuum valve, item (8) not functioning.	<ol style="list-style-type: none"> 1. Vacuum valve springs, item (25), not connected or broken. 2. Broken pull cable, item (23). 	<p>Reconnect, or, if broken, replace.</p> <p>Replace.</p>

PULL CABLE MECHANISM

PROBLEM	POSSIBLE CAUSE	SOLUTION
Direction control lever arm, item (20), does not lock in the up position.	<ol style="list-style-type: none"> 1. One or both shaft collar set screws, item (22) are loose. 2. Too much clearance between pull cable cam, item (18), and stop bracket, item (16). 3. Damaged plunger, item (19). 	<p>Retighten set screws, item (22).</p> <p>Add spacer(s), item (17), as required to bring cam, item (18) flush with stop bracket, item (28)</p> <p>Replace.</p>
Pull cable, item (23), jumps out of pull cable cam, item (18), in down position.	<ol style="list-style-type: none"> 1. Loose or broken vacuum valve springs, item (25). 2. Vacuum valve, item (8), is too low when in up position. 	<p>Reconnect or, if broken, replace.</p> <p>Readjust. See vacuum valve pull cable adjustment procedure.</p>

SUPERNOVA 800 & I200

TROUBLE SHOOTING

BRUSH MOTOR REVERSE

PROBLEM	POSSIBLE CAUSE	SOLUTION
Brush Motor fails to reverse when direction control lever arm, item (20), is in the up (backward) position.	<ol style="list-style-type: none">1. Vacuum valve, item (8) does not reach its normal up position.2. Defective reverse switch, item (11).3. Loose switch connector, item (26).	<p>Adjust the pull cable jacket, item (1), and switches, item (11), as shown in the adjustment instruction section.</p> <p>Replace.</p> <p>Check color coding before connecting terminals. Reconnect terminals to obtain proper connection. Replace wire assembly if necessary.</p>
Brush Motor fails to reverse when direction control lever arm, item (20), in the down (forward) position.	<ol style="list-style-type: none">1. Vacuum valve, item (8) does not reach its normal down position.2. Defective reverse switch, item (11).3. Loose switch connector, item (26).	<p>Adjust the pull cable jacket, item (1), and switches, item (11), as shown in the adjustment instruction section. Remove any dirt or foreign objects from between the vacuum valve, item (16), in down position, and the bumper, item (29). Replace vacuum valve springs, item (25), if broken or stretched.</p> <p>Replace.</p> <p>Check color coding before connecting terminals. Reconnect terminals to obtain proper connection. Replace wire assembly if necessary.</p>

SUPERNOVA 800 & 1200
VACUUM VALVE AND BRUSH MOTOR REVERSE SWITCH
ADJUSTMENT PROCEDURES

VACUUM VALVE PULL CABLE ADJUSTMENT _____

1. Drain the solution tank, and remove the recovery pails from the machine.
2. Make sure the power cord is unplugged from the power receptacle.
3. Shift the direction control lever arm to the up (backward) position.
4. Open the machine's motor housing by actuating the latch handle lever and lifting the motor housing from the front.
5. To MOVE THE VACUUM VALVE, item (8), UP:
 - Step 1. Loosen the lower pull cable jacket nut, item (4).
 - Step 2. Tighten upper pull cable jacket nut, Item (2), until the desired position is reached. [In its normal position, the upper edge of the spring bracket, item (5), is flush with the upper edge of the vacuum valve guide, item (6).]
 - Step 3. Retighten lower cable jacket nut, item (4).
6. To MOVE THE VACUUM VALVE, item (8), DOWN:
 - Step 1. Loosen the upper cable jacket nut, item (2), until the vacuum valve, item (8), reaches the desired position.
 - Step 2. Tighten the lower cable jacket nut, item (4).

BRUSH MOTOR REVERSING SWITCHES ADJUSTMENT _____

1. Drain the solution tank, and remove the recovery pail from the machine.
2. Make sure the power cord is unplugged from the power receptacle.
3. Shift the direction control lever arm to the up (backward) position.
4. Adjust the pull cable, if required, to insure that the vacuum valve is in the correct position. (See vacuum valve pull cable adjustment procedure.)
5. **Make the adjustment:**
 - Step 1. Slightly loosen the two switch nuts, item (7), located on the switch bracket, item (9).
 - Step 2. Rotate the three switches by pushing their bodies, item (11), toward the timing bar plate, item (27), until the switch actuating arm rollers, item (10), touch the timing bar plate, Item (27).
 - Step 3. While holding the switches, item (11), in position, retighten the two switch nuts, item (7).